

# ABSOLUTE, DIFFERENTIAL AND GAUGE PRESSURE TRANSMITTER FOR REMOTE SEAL(S)

**DATA SHEET**
**FKB, FKB, FKM...F**

The FCX-AII series absolute, differential and gauge pressure transmitters accurately measures and transmits proportional 4 to 20mA signal. The transmitters utilize the unique micromachined capacitive silicon sensor with state-of-the-art microprocessor technology to provide exceptional performance and functionality.

## FEATURES

### 1. High accuracy

0.065 % accuracy is a standard feature for differential and gauge pressure models and 0.2% accuracy for absolute pressure models.

The microcapacitance silicon sensor assures this feature for all elevated or suppressed calibration ranges without additional adjustment.

### 2. Minimum environmental influence

The "Advanced Floating Cell" design which protects the pressure sensor against changes in temperature, and over-pressure substantially reduces total measurement error in actual field applications.

### 3. Fuji/HART® bilingual communications protocol

FCX-AII series transmitter offers bilingual communications to speak both Fuji proprietary protocol and HART®. Any HART® compatible devices can communicate with FCX-AII.

### 4. Application flexibility

Various options that render the FCX-AII suitable for almost any process applications include:

- Full range of hazardous area approvals
- Built-in RFI filter and lightning arrester
- 5-digit LCD meter with engineering unit
- Stainless steel electronics housing
- Wide selection of materials
- High temperature, high vacuum seals

### 5. Burnout current flexibility (Under Scale: 3.2 to 4.0mA, Over Scale: 20.0 to 22.5mA)

Burnout signal level is adjustable using Model FXW or Hand Held Communicator (HHC) to comply with NAMUR NE43.

### 6. Dry calibration without reference pressure

Thanks to the best combination of unique construction of mechanical parts (Sensor unit) and high performance electronics circuit (Electronics unit), reliability of dry calibration without reference pressure is at equal level as wet calibration.

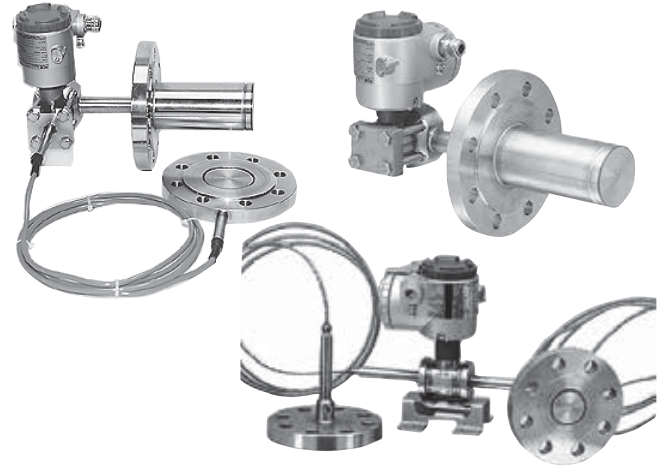

## SPECIFICATIONS

### Functional specifications

#### Type:

- FKB : differential pressure transmitter with remote seal(s)
- FKB : gauge pressure transmitter with remote seal
- FKM : absolute pressure transmitter with remote seal

#### Service :

Liquid, gas, or vapour

#### Span, range, and overrange limit :

Model	Span limits		Range limits
	Minimum	Maximum	
<b>FKD</b>			
	(mbar)	(mbar)	(mbar)
F□D□□3	3.2	320	± 320
F□D□□5	13	1300	± 1300
F□D□□6	50	5000	± 5000
F□D□□8	300	30000	± 30000
F□D□□9	2000	200000	±200000
<b>FKB</b>			
	(bar)	(bar)	(bar)
F□B□□1	0,013	1,3	-1 to + 1,3
F□B□□2	0,05	5	-1 to + 5
F□B□□3	0,3	30	-1 to + 30
F□B□□4	1	100	-1 to + 100
F□B□□5	5	500	-1 to + 500
<b>FKM</b>			
	(bar abs)	(bar abs)	(bar abs)
F□M□□1	0,016	0,16	0 to +0,16
F□M□□2	0,013	1,3	0 to +1,3
F□M□□3	0,05	5	0 to +5
F□M□□4	0,3	30	0 to +30
F□M□□5	1	100	0 to +100

Remark: To minimize environmental influence, span should be greater than 1/40 of the max. span in most applications.

**Output signal :**

4 to 20mA DC with digital signal superimposed on the 4 to 20mA signal.

**Power supply :**

Transmitter operates on 10.5V to 45V DC at transmitter terminals.

10.5V to 32V DC for the units with optional arrester.

**Load limitations :** see figure below

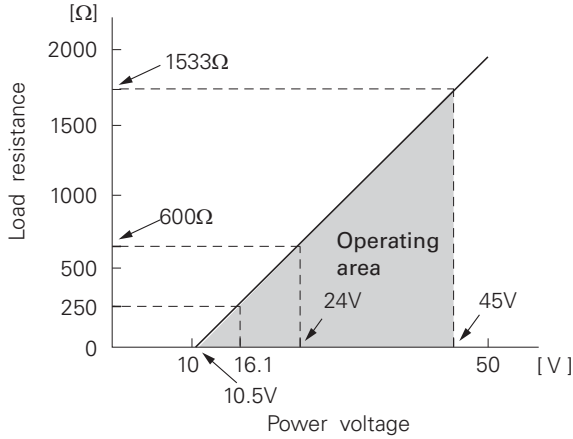

Note: For communication with HHC<sup>(1)</sup> min. of 250Ω is required.

**Hazardous locations :**

Authority (Digit 10 = )	Intrinsic safety																		
ATEX (K)	Ex II 1 G Ex ia IIC T5 (-40°C ≤ Ta ≤ +50 °C) Ex ia IIC T4 (-40°C ≤ Ta ≤ +70 °C) IP66/67 Entity Parameters: Ui ≤ 28 Vdc, Ii ≤ 94.3 mA, Pi ≤ 0.66 W Ci = 36 nF/26 nF for models with/without Arrester Li = 0.7 mH/0.6 mH for models with/without Analog Indicator																		
Factory Mutual (H)	Class I II III Div.1 Groups A, B, C, D, E, F, G T4 Entity Type 4X <table border="1"> <thead> <tr> <th>Model code</th> <th>13th digit</th> <th>Tamb</th> </tr> </thead> <tbody> <tr> <td>A,B,C,D,J</td> <td>Y,G,N</td> <td>-40°C to +85°C</td> </tr> <tr> <td>L,P,M,1,2,3</td> <td>Y,G,N</td> <td>-20°C to +80°C</td> </tr> <tr> <td>Q,S,N,4,5,6</td> <td>Y,G,N</td> <td>-20°C to +60°C</td> </tr> <tr> <td>E,F,G,H,K</td> <td>Y,G,N</td> <td>-40°C to +60°C</td> </tr> <tr> <td>-</td> <td>W,A,D</td> <td>-10°C to +60°C</td> </tr> </tbody> </table> Entity Parameters: Vmax=42.4V, Imax=113mA, Pi=1W, Ci=35.98nF, Li=0.694mH	Model code	13th digit	Tamb	A,B,C,D,J	Y,G,N	-40°C to +85°C	L,P,M,1,2,3	Y,G,N	-20°C to +80°C	Q,S,N,4,5,6	Y,G,N	-20°C to +60°C	E,F,G,H,K	Y,G,N	-40°C to +60°C	-	W,A,D	-10°C to +60°C
Model code	13th digit	Tamb																	
A,B,C,D,J	Y,G,N	-40°C to +85°C																	
L,P,M,1,2,3	Y,G,N	-20°C to +80°C																	
Q,S,N,4,5,6	Y,G,N	-20°C to +60°C																	
E,F,G,H,K	Y,G,N	-40°C to +60°C																	
-	W,A,D	-10°C to +60°C																	
CSA (J)	Ex ia Class I, Groups A, B, C and D; Class II, Groups E, F and G; Class III Per drawing TC 522873 Temp. code T5 for Tamb max = +50°C Temp. code T4 for Tamb max = +70°C Entity Parameters: Vmax = 28 Vdc, Imax = 94.3 mA, Pmax = 0.66 W Ci = 36 nF/25 nF for models with/without Arrester Li = 0.7 mH/0.6 mH for models with/without Analog Indicator																		
IECEX (T)	Ex ia IIC T5 (-40°C ≤ Ta ≤ +50 °C) Ex ia IIC T4 (-40°C ≤ Ta ≤ +70 °C) IP66/67 Entity Parameters: Ui ≤ 28 Vdc, Ii ≤ 94.3 mA, Pi ≤ 0.66 W Ci = 36 nF/26 nF for models with/without Arrester Li = 0.7 mH/0.6 mH for models with/without Analog Indicator																		

Authority	Flameproof
ATEX (X)	Ex II 2 GD Ex d IIC T6 (-40°C ≤ Ta ≤ +65 °C) Ex d IIC T5 (-40°C ≤ Ta ≤ +85 °C) Ex tD A21 IP66/67 T 85°C Ex tD A21 IP66/67 T 100°C Electrical ratings Model Without arrester: Ui ≤ 45 Vdc, 4-20 mA loop powered, Pi ≤ 1.0125 W Model With arrester: Ui ≤ 32 Vdc, 4-20 mA loop powered, Pi ≤ 1.0125 W
Factory Mutual (D)	Class I Div.1 Groups B, C, D T6 Type 4X Class II III Div.1 Groups E, F, G T6 Type 4X Tamb max = +60°C
CSA (E)	Class I, Groups C and D; Class II, Groups E, F and G ; Class III Maximum ambient temperature 85°C Maximum working pressure 50 Mpa Electrical ratings Model Without arrester: Ui ≤ 45 Vdc, 4-20 mA Model With arrester: Ui ≤ 32 Vdc, 4-20 mA Note: "Seal not required"
IECEX (R)	Ex d IIC T6 (-40°C ≤ Ta ≤ +65 °C) Ex d IIC T5 (-40°C ≤ Ta ≤ +85 °C) DIP A21 IP66/67 T 85°C DIP A21 IP66/67 T 100°C Electrical ratings Model Without arrester: Ui ≤ 45 Vdc, 4-20 mA loop powered, Pi ≤ 1.0125 W Model With arrester: Ui ≤ 32 Vdc, 4-20 mA loop powered, Pi ≤ 1.0125 W

Authority (Digit 10 = )	Type n Nonincendive																		
ATEX (P)	Ex II 3 G Ex nA II T5 (-40°C ≤ Ta ≤ +70 °C) IP66/67 Electrical ratings Model Without arrester: Ui ≤ 45 Vdc, 4-20 mA loop powered, Pi ≤ 1.0125 W Model With arrester: Ui ≤ 32 Vdc, 4-20 mA loop powered, Pi ≤ 1.0125 W Optional Analog indicator is not available for type "n"																		
Factory Mutual (H)	Class I II III Div.2 Groups A, B, C, D, F, G T4 Entity Type 4X <table border="1"> <thead> <tr> <th>Model code</th> <th>13th digit</th> <th>Tamb</th> </tr> </thead> <tbody> <tr> <td>A,B,C,D,J</td> <td>Y,G,N</td> <td>-40°C to +85°C</td> </tr> <tr> <td>L,P,M,1,2,3</td> <td>Y,G,N</td> <td>-20°C to +80°C</td> </tr> <tr> <td>Q,S,N,4,5,6</td> <td>Y,G,N</td> <td>-20°C to +60°C</td> </tr> <tr> <td>E,F,G,H,K</td> <td>Y,G,N</td> <td>-40°C to +60°C</td> </tr> <tr> <td>-</td> <td>W,A,D</td> <td>-10°C to +60°C</td> </tr> </tbody> </table>	Model code	13th digit	Tamb	A,B,C,D,J	Y,G,N	-40°C to +85°C	L,P,M,1,2,3	Y,G,N	-20°C to +80°C	Q,S,N,4,5,6	Y,G,N	-20°C to +60°C	E,F,G,H,K	Y,G,N	-40°C to +60°C	-	W,A,D	-10°C to +60°C
Model code	13th digit	Tamb																	
A,B,C,D,J	Y,G,N	-40°C to +85°C																	
L,P,M,1,2,3	Y,G,N	-20°C to +80°C																	
Q,S,N,4,5,6	Y,G,N	-20°C to +60°C																	
E,F,G,H,K	Y,G,N	-40°C to +60°C																	
-	W,A,D	-10°C to +60°C																	
CSA (J)	Class I Div.2 Groups A, B, C, D Class II Div.2 Groups E, F, G Class III Div.2 Temp Code T5 Tamb max = +50°C Temp Code T4 Tamb max = +70°C Entity Parameters: Vmax = 28 Vdc, Imax = 94.3 mA, Pmax = 0.66 W Ci = 36 nF/25 nF for models with/without Arrester Li = 0.7 mH/0.6 mH for models with/without Analog Indicator																		
IECEX (Q)	Ex nA II T5 (-40°C ≤ Ta ≤ +70 °C) IP66/67 Electrical ratings Model Without arrester: Ui ≤ 45 Vdc, 4-20 mA loop powered, Pi ≤ 1.0125 W Model With arrester: Ui ≤ 32 Vdc, 4-20 mA loop powered, Pi ≤ 1.0125 W Optional Analog indicator is not available for type "n"																		

**Zero/span adjustment :**

Zero and span are adjustable from the HHC<sup>(1)</sup>. Zero and span are also adjustable externally from the adjustment screw.

**Damping :**

Adjustable from HHC or local adjustment unit with LCD display.

The time constant is adjustable between 0 to 32 sec

**Zero elevation/suppression :**

Zero can be elevated or suppressed within the specified range limit of each sensor model.

**Normal/reverse action :**

Selectable from HHC<sup>(1)</sup>.

**Indication :**

Analog indicator or 5-digit LCD meter, as specified.

**Burnout direction :** Selectable from HHC<sup>(1)</sup>

If self-diagnostic detect transmitter failure, the analog signal will be driven to either "Output Hold", "Output Overscale" or "Output Underscale" modes.

"Output Hold":

Output signal is hold as the value just before failure happens.

"Output Overscale":

Adjustable within the range 20.0mA to 22.5mA from HHC<sup>(1)</sup>

"Output Underscale":

Adjustable within the range 3.2mA to 4.0mA from HHC<sup>(1)</sup>

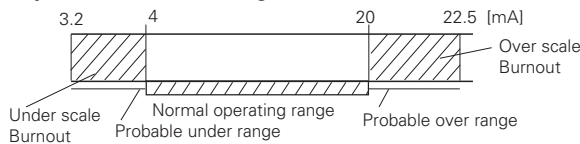

Output Limits conforming the NAMUR NE43 by order.

**Loop-check output :**

Transmitter can be configured to provide constant signal 3.2mA through 22.5mA by HHC<sup>(1)</sup>.

**Temperature limit :**

- Ambient: -40 to +85°C
- 20 to +80°C (for LCD indicator)
- 40 to +60°C (for arrester option)
- 20 to +60°C (for fluorinated oil fill transmitter)

For explosionproof units (flameproof or intrinsic safety), ambient temperature must be within the limits specified by each standard.

Process: Check in the seal - datasheet with the specific temperature conditions.

Storage: -40 to +90°C

**Humidity limit :**

0 to 100% RH

**Communication :**

With HHC<sup>(1)</sup> (model FXW, consult DS No.EDS8-47), following items can be remotely displayed or configured.

Note: HHC's version must be higher than 7.0 (or FXW□□□□1-□4), for FCX -AII for supporting these items : "Saturate current", "Write protect".

Items	Fuji Protocol with FXW		Hart Protocol	
	Display	Set	Display	Set
Tag No.	✓	✓	✓	✓
Model No.	✓	✓	—	—
Serial No. & Software Version	✓	—	✓	—
Engineering unit	✓	✓	✓	✓
Range limit	✓	—	✓	—
Measuring range	✓	✓	✓	✓
Damping	✓	✓	✓	✓
Output mode	Linear	✓	✓	✓
	Square root	✓	✓	✓

Burnout direction	✓	✓	✓	✓
Calibration	✓	✓	✓	✓
Output adjust	—	✓	—	✓
Data	✓	—	✓	—
Self diagnoses	✓	—	✓	—
Printer (In case of FXW with printer option)	✓	—	—	—
External switch lock	✓	✓	✓	✓
Transmitter display	✓	✓	✓	✓
Linearize*	✓	✓	—	—
Rerange	✓	✓	✓	✓
Saturate current	✓	✓	✓	✓
Write protect	✓	✓	✓	✓
History				
- Calibration history	✓	✓	✓	✓
- Ambient temperature history	✓	—	✓	—

(Note) (1) HHC: Hand Held Communicator

**\*Local configurator with LCD display (option) :**

Local configurator with 3 push button and LCD display can support all items (Fuji Protocol list) except "Linearize" function.

**Programmable output linearization function :**

Output signal can be characterized with "14 points linear approximation function" from HHC<sup>(1)</sup>.

**Performance specifications**

Reference conditions, silicone oil fill, 316SS isolating diaphragms, 4 to 20mA analog output.

**Accuracy rating :**

(including linearity, hysteresis, and repeatability)

For span greater than 1/10 of URL :

± 0,065% of calibrated span (FKB & FKD)

± 0,1% of calibrated span for FKB□□5VF

± 0,2% of calibrated span for FKM

For span smaller than 1/10 of URL :

± (0,015 + 0,05 x 0,1 x URL/span) % of span (FKB & FKD)

± (0,1 + 0,1 x 0,1 x URL/span) % of span (FKM)

**Stability :**

± 0.2% of upper range limit (URL) for 10 years.

**Linearity :**

0,05% of calibrated span (FKB & FKD)

0,1% of calibrated span (FKM)

**Temperature effect :**

Effect per 28°C change between -40°C and +85°C

Model FKM :

Zero shift : ±(0,125 + 0,1 x URL/span) % of URL

Total effect : ±(0,15 + 0,1 x URL/span) % of URL

Model FKB & FKD :

Zero shift : ±(0,075 + 0,0125% URL/span) % of URL

Total effect : ±(0,095 + 0,0125% URL/span) % of URL

**Static pressure effect (FKD) :**

Zero shift : ± 0,035% of URL for 100 bar

**Overrange effect (FKB & FKM) :**

Zero shift : 0,2% of URL, for any overrange pressures (limited to the max. overrange pressure)

**Overrange effect (FKD) :**

Zero shift : ± 0,15% of URL / 160 bar limit

**Supply voltage effect :**

Less than 0.005% of calibrated span per 1V

**RFI effect :**

< 0,2% of URL for the frequencies of 20 to 1000 MHz and field strength of 10 V/m when electronic housing covers are on (Classification : 2-abc : 0,2% of span according SAMA PMC 33.1)

**Update rate :** 60 msec

**Response time :** (at 63,2% of output signal)

Time constant : 300 msec (F#D span code "3")

Time constant : 200 msec (other spans and F#B, F#M)

Dead time : 300 msec

Response time = time constant + dead time

**Mounting position effect :**

Zero shift : < 12 mm WC for 10° incline in any position. This shift can be corrected with the zero adjustment.

This effect is doubled for fluorinated oil filling.

No influence on span adjustment.

**Vibration effect :**

> ±0,25% of span for spans greater than 1/10 of URL.

Frequency 10 to 150Hz, acceleration 39,2m/sec<sup>2</sup>.

**Material fatigue :** Please consult Fuji Electric

**Dielectric strength:**

500V AC, 50/60Hz 1 min., between circuit and earth.

**Insulation resistance :**

More than 100MΩ / 500V DC.

**Internal resistance for external field indicator :**

12 Ω maxi (connected to test terminal CK+ and CK-)

**Physical specifications**

**Electrical connections :**

1/2»-14 NPT, Pg 13,5 or M20 x 1,5

**Process-wetted parts material :**

Diaphragm:

316L stainless steel, Hastelloy-C, Monel, Tantalum, Titanium or Zirconium

Flange face:

316 stainless steel, Hastelloy-C, Monel, Tantalum, Titanium or Zirconium

Extension:

316 stainless steel, Hastelloy-C  
(Refer to "Code symbols")

**Non-wetted parts material :**

Electronics housing:

Low copper die-cast aluminum alloy finished with polyester coating (standard), or 316 stainless steel as specified.

Capillary:

In case of 11th code "D, E, L, F, M, N, P", PVC armored stainless steel.

In case of 11th code "Q, R, S, T, V, W, X", stainless steel armored stainless steel.

Mounting flange:

304 stainless steel or carbon steel, as specified

Fill fluid:

Silicone oil (standard) or fluorinated oil

Mounting bracket:

304 stainless steel

**Environmental protection :**

IEC IP67 and NEMA 6/6P

**Mounting :**

On 60.5mm (JIS 50A) pipe using mounting bracket, direct wall mounting

**Mass {weight} :**

Transmitter alone : 5kg without options.

Add: 0.5kg for mounting bracket

4.5kg for ss housing (option)

1.5kg per 50mm extension of diaphragm

**Diaphragm seal(s) :**

A comprehensive selection of seals can be chosen in accordance with the specific seal (see datasheet).

**Optional features**

**Indicator :**

A plug-in analog indicator.

An optional 5-digit LCD meter with engineering unit is also available.

**Local configurator with LCD display :**

An optional 5 digits LCD meter with 3 push buttons can support items as using communication with FXW.

**Arrester :**

A built-in arrester protects the electronics from lightning surges.

Lightning surge immunity: 4kV (1.2 × 50µs)

**Optional tag plate :**

An extra stainless steel tag for customer tag data is wired to the transmitter.

**Vacuum service :**

Special silicone oil and filling procedure are applied.

See Fig.1

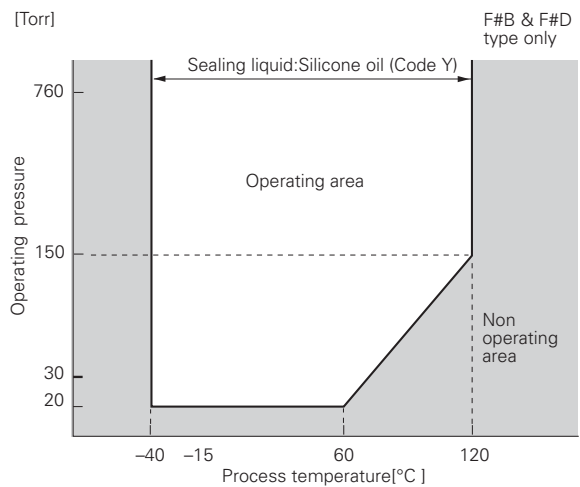

**Fig. 1 Relation between process temperature and operating pressure**

**ACCESSORIES**

**Hand-held communicator :**

(Model FXW, refer to Data Sheet No. EDS8-47)

# CODE SYMBOLS - FKB

1	2	3	4	5	6	7	8	9	10	11	12	13	DESCRIPTION																																																																				
F	K	B				V	F						<b>Type</b> Smart, 4-20 mA dc + Fuji/Hart® digital signal																																																																				
													<b>Conduit connection</b> 1/2"-14NPT Pg 13.5 M20 x 1.5																																																																				
													<b>Diaphragm seal rating</b> PN 25 PN 20 - 150 Lbs PN 50 - 300 Lbs PN 40 PN 16 PN 100 - 600Lbs PN 150 - 900Lbs PN 250 - 1500Lbs PN 420 - 2500Lbs																																																																				
													(*1) <b>Spans</b> (*2) 0 to 0.013/1.3 bar (*3) 0 to 0.05/5 bar (*4) 0 to 0.3/30 bar (*4) 0 to 1/100 bar (*4) 0 to 5/500 bar																																																																				
													<b>Indicator, arrester and initial setting</b> <table border="1"> <thead> <tr> <th>Indicator</th><th>Arrester</th><th>Initial setting</th></tr> </thead> <tbody> <tr><td>V F - A</td><td>None</td><td></td></tr> <tr><td>V F - B</td><td>None</td><td></td></tr> <tr><td>V F - D</td><td>None</td><td></td></tr> <tr><td>V F - J</td><td>None</td><td>4-20mA DC</td></tr> <tr><td>V F - E</td><td>Yes</td><td>+</td></tr> <tr><td>V F - F</td><td>Yes</td><td>Hart® /Fuji</td></tr> <tr><td>V F - H</td><td>Yes</td><td>digital signal</td></tr> <tr><td>V F - K</td><td>Yes</td><td>"SMART"</td></tr> <tr><td>V F - 1</td><td>None</td><td></td></tr> <tr><td>V F - 2</td><td>None</td><td></td></tr> <tr><td>V F - 4</td><td>Yes</td><td></td></tr> <tr><td>V F - 5</td><td>Yes</td><td></td></tr> </tbody> </table>	Indicator	Arrester	Initial setting	V F - A	None		V F - B	None		V F - D	None		V F - J	None	4-20mA DC	V F - E	Yes	+	V F - F	Yes	Hart® /Fuji	V F - H	Yes	digital signal	V F - K	Yes	"SMART"	V F - 1	None		V F - 2	None		V F - 4	Yes		V F - 5	Yes																														
Indicator	Arrester	Initial setting																																																																															
V F - A	None																																																																																
V F - B	None																																																																																
V F - D	None																																																																																
V F - J	None	4-20mA DC																																																																															
V F - E	Yes	+																																																																															
V F - F	Yes	Hart® /Fuji																																																																															
V F - H	Yes	digital signal																																																																															
V F - K	Yes	"SMART"																																																																															
V F - 1	None																																																																																
V F - 2	None																																																																																
V F - 4	Yes																																																																																
V F - 5	Yes																																																																																
													<b>Approvals for hazardous locations (consult FUJI for availability)</b> None (Standard) ATEX - Flameproof enclosures (digit 4 = "M, P, R, T" & "W" only) ATEX - Intrinsic Safety (*8) FM - Explosion-Proof (digit 4 = "P" & "T" only) CSA - Explosion-Proof (digit 4 = "P" & "T" only) FM - Intrinsic Safety and Non Incendive CSA - Intrinsic Safety ATEX - Type "n" (digit 9 = A, E, 1, 2, 3, 4, 5 & 6 only) IECEx - Type "n" (digit 9 = A, E, 1, 2, 3, 4, 5 & 6 only) IECEx - Flameproof enclosures (digit 4 = "M, P, R, T" & "W" only) IECEx - Intrinsic Safety CSA - Explosion-Proof & Intrinsic Safety combined approval (digit 4 = "P" & "T" only) ATEX - Flameproof enclosures & Intrinsic Safety combined approval (digit 4 = "M, P, R, T" & "W" only) IECEx - Flameproof enclosures & Intrinsic Safety combined approval (digit 4 = "M, P, R, T" & "W" only) FM - Explosion-Proof & Intrinsic Safety combined approval (digit 4 = "P" & "T" only)																																																																				
													(*5) <b>Mounting design</b> (*5) <b>Ambient temperature correction</b> <table border="1"> <thead> <tr> <th>Mounting design</th><th>Ambient temperature correction</th></tr> </thead> <tbody> <tr><td>B</td><td>Capillary Transmitter and diaphragm seal assembly</td></tr> <tr><td>L</td><td>Rigid - long design Transmitter and diaphragm seal assembly</td></tr> <tr><td>M</td><td>Rigid - short design Transmitter and diaphragm seal assembly</td></tr> <tr><td>G</td><td>Capillary Transmitter</td></tr> <tr><td>S</td><td>Rigid - long design Transmitter</td></tr> <tr><td>T</td><td>Rigid - short design Transmitter</td></tr> </tbody> </table>	Mounting design	Ambient temperature correction	B	Capillary Transmitter and diaphragm seal assembly	L	Rigid - long design Transmitter and diaphragm seal assembly	M	Rigid - short design Transmitter and diaphragm seal assembly	G	Capillary Transmitter	S	Rigid - long design Transmitter	T	Rigid - short design Transmitter																																																						
Mounting design	Ambient temperature correction																																																																																
B	Capillary Transmitter and diaphragm seal assembly																																																																																
L	Rigid - long design Transmitter and diaphragm seal assembly																																																																																
M	Rigid - short design Transmitter and diaphragm seal assembly																																																																																
G	Capillary Transmitter																																																																																
S	Rigid - long design Transmitter																																																																																
T	Rigid - short design Transmitter																																																																																
													<b>Cell flange design</b> <b>SS parts</b> <table border="1"> <thead> <tr> <th>Operating pressure (bar)</th><th>Bolts/nuts</th><th>SS tag plate</th><th>SS housing &amp; mounting bracket</th></tr> </thead> <tbody> <tr><td>1 Y (*7) (*6) p ≤ 50 bar</td><td>none</td><td>None</td><td>None</td></tr> <tr><td>2 Y (*7) (*6) p ≤ 50 bar</td><td>none</td><td>Yes</td><td>None</td></tr> <tr><td>3 Y (*7) (*6) p ≤ 50 bar</td><td>none</td><td>None</td><td>Yes</td></tr> <tr><td>4 Y (*7) (*6) p ≤ 50 bar</td><td>none</td><td>Yes</td><td>Yes</td></tr> <tr><td>Y Y (*7) 50 &lt; p ≤ 100</td><td>carbon steel</td><td>None</td><td>None</td></tr> <tr><td>B Y (*7) 50 &lt; p ≤ 100</td><td>carbon steel</td><td>Yes</td><td>None</td></tr> <tr><td>C Y (*7) 50 &lt; p ≤ 100</td><td>carbon steel</td><td>None</td><td>Yes</td></tr> <tr><td>E Y (*7) 50 &lt; p ≤ 100</td><td>carbon steel</td><td>Yes</td><td>Yes</td></tr> <tr><td>A Y (*7) p ≤ 100 bar</td><td>SS 316/SS 316</td><td>None</td><td>None</td></tr> <tr><td>D Y (*7) p ≤ 100 bar</td><td>SS 316/SS 316</td><td>Yes</td><td>None</td></tr> <tr><td>F Y (*7) p ≤ 100 bar</td><td>SS 316/SS 316</td><td>None</td><td>Yes</td></tr> <tr><td>G Y (*7) p ≤ 100 bar</td><td>SS 316/SS 316</td><td>Yes</td><td>Yes</td></tr> <tr><td>H Y (*7) (*9) p = 100 bar max</td><td>SS 660/SS 660</td><td>None</td><td>None</td></tr> <tr><td>J Y (*7) (*9) p = 100 bar max</td><td>SS 660/SS 660</td><td>Yes</td><td>None</td></tr> <tr><td>K Y (*7) (*9) p = 100 bar max</td><td>SS 660/SS 660</td><td>None</td><td>Yes</td></tr> <tr><td>L Y (*7) (*9) p = 100 bar max</td><td>SS 660/SS 660</td><td>Yes</td><td>Yes</td></tr> </tbody> </table>	Operating pressure (bar)	Bolts/nuts	SS tag plate	SS housing & mounting bracket	1 Y (*7) (*6) p ≤ 50 bar	none	None	None	2 Y (*7) (*6) p ≤ 50 bar	none	Yes	None	3 Y (*7) (*6) p ≤ 50 bar	none	None	Yes	4 Y (*7) (*6) p ≤ 50 bar	none	Yes	Yes	Y Y (*7) 50 < p ≤ 100	carbon steel	None	None	B Y (*7) 50 < p ≤ 100	carbon steel	Yes	None	C Y (*7) 50 < p ≤ 100	carbon steel	None	Yes	E Y (*7) 50 < p ≤ 100	carbon steel	Yes	Yes	A Y (*7) p ≤ 100 bar	SS 316/SS 316	None	None	D Y (*7) p ≤ 100 bar	SS 316/SS 316	Yes	None	F Y (*7) p ≤ 100 bar	SS 316/SS 316	None	Yes	G Y (*7) p ≤ 100 bar	SS 316/SS 316	Yes	Yes	H Y (*7) (*9) p = 100 bar max	SS 660/SS 660	None	None	J Y (*7) (*9) p = 100 bar max	SS 660/SS 660	Yes	None	K Y (*7) (*9) p = 100 bar max	SS 660/SS 660	None	Yes	L Y (*7) (*9) p = 100 bar max	SS 660/SS 660	Yes	Yes
Operating pressure (bar)	Bolts/nuts	SS tag plate	SS housing & mounting bracket																																																																														
1 Y (*7) (*6) p ≤ 50 bar	none	None	None																																																																														
2 Y (*7) (*6) p ≤ 50 bar	none	Yes	None																																																																														
3 Y (*7) (*6) p ≤ 50 bar	none	None	Yes																																																																														
4 Y (*7) (*6) p ≤ 50 bar	none	Yes	Yes																																																																														
Y Y (*7) 50 < p ≤ 100	carbon steel	None	None																																																																														
B Y (*7) 50 < p ≤ 100	carbon steel	Yes	None																																																																														
C Y (*7) 50 < p ≤ 100	carbon steel	None	Yes																																																																														
E Y (*7) 50 < p ≤ 100	carbon steel	Yes	Yes																																																																														
A Y (*7) p ≤ 100 bar	SS 316/SS 316	None	None																																																																														
D Y (*7) p ≤ 100 bar	SS 316/SS 316	Yes	None																																																																														
F Y (*7) p ≤ 100 bar	SS 316/SS 316	None	Yes																																																																														
G Y (*7) p ≤ 100 bar	SS 316/SS 316	Yes	Yes																																																																														
H Y (*7) (*9) p = 100 bar max	SS 660/SS 660	None	None																																																																														
J Y (*7) (*9) p = 100 bar max	SS 660/SS 660	Yes	None																																																																														
K Y (*7) (*9) p = 100 bar max	SS 660/SS 660	None	Yes																																																																														
L Y (*7) (*9) p = 100 bar max	SS 660/SS 660	Yes	Yes																																																																														

**Notes\* :**

- Turn down of 100:1 is possible, but should be used at the span greater than 1/10 of the maximum span for better performance.
- Consult FUJI for your application with the specific operating conditions
- For DN < 50 consult FUJI for your application with the specific operating conditions
- Flange rating according max. operating pressure - for DN < 50 flange size and / or PN > 150, consult FUJI
- Transmitter with capillary design has a standard mounting bracket - Rigid mounting design are always without mounting bracket
- If direct mounted seal design is required, bolts are necessary even when p < 50bar
- Standard fill fluid of measuring cells : silicone oil - Other fill fluids : upon request
- Code "D & V" FM approval only possible with electrical connection 1/2"-14 NPT
- Our stainless steel bolts/nuts in SS 660 are in conformity with the NACE requirements and must be used for NACE service.

CODE SYMBOLS - FKD

1	2	3	4	5	6	7	8	9	10	11	12	13	DESCRIPTION																																																																				
F	K	D		V	F			Y																																																																									
													(*5) <b>Type</b> Differential pressure transmitter - Smart, 4-20 mAdc + Fuji/Hart® digital signal																																																																				
													<b>Conduit connection</b> 1/2"-14NPT Pg 13.5 M20 x 1.5																																																																				
													<b>Diaphragm seal rating</b> PN 25 PN 20 - 150 Lbs PN 50 - 300 Lbs PN 40 PN 16 PN 100 - 600Lbs PN 150 - 900 lbs PN 250 - 1500 lbs PN 420 - 2500 lbs																																																																				
													(*1) <b>Spans</b> (*2) 0 to 3,2/320 mbar (*2) 0 to 0,013/1,3 bar (*2) 0 to 0,05/5 bar (*) 0 to 0,3/30 bar (*) 0 to 2/200 bar																																																																				
													<b>Indicator, arrester and initial setting</b>																																																																				
													<table border="1"> <thead> <tr> <th>Indicator</th><th>Arrester</th><th>Initial setting</th></tr> </thead> <tbody> <tr> <td>None</td><td>None</td><td></td></tr> <tr> <td>Analog, 0-100% linear scale</td><td>None</td><td></td></tr> <tr> <td>Analog, 0-100% √ scale</td><td>None</td><td>4-20mA DC</td></tr> <tr> <td>Analog, Custom scale</td><td>None</td><td>+</td></tr> <tr> <td>Analog, double scale</td><td>None</td><td>Hart ®/Fuji</td></tr> <tr> <td>None</td><td>Yes</td><td>digital signal</td></tr> <tr> <td>Analog, 0-100% linear scale</td><td>Yes</td><td>"SMART"</td></tr> <tr> <td>Analog, 0-100% √ scale</td><td>Yes</td><td></td></tr> <tr> <td>Analog, Custom scale</td><td>Yes</td><td></td></tr> <tr> <td>Analog, double scale</td><td>Yes</td><td></td></tr> <tr> <td>Digital, 0-100%</td><td>None</td><td></td></tr> <tr> <td>Digital, Custom scale</td><td>None</td><td></td></tr> <tr> <td>Digital, 0-100% √ scale</td><td>None</td><td></td></tr> <tr> <td>Digital, 0-100%</td><td>Yes</td><td></td></tr> <tr> <td>Digital, Custom scale</td><td>Yes</td><td></td></tr> <tr> <td>Digital, 0-100% √ scale</td><td>Yes</td><td></td></tr> </tbody> </table>	Indicator	Arrester	Initial setting	None	None		Analog, 0-100% linear scale	None		Analog, 0-100% √ scale	None	4-20mA DC	Analog, Custom scale	None	+	Analog, double scale	None	Hart ®/Fuji	None	Yes	digital signal	Analog, 0-100% linear scale	Yes	"SMART"	Analog, 0-100% √ scale	Yes		Analog, Custom scale	Yes		Analog, double scale	Yes		Digital, 0-100%	None		Digital, Custom scale	None		Digital, 0-100% √ scale	None		Digital, 0-100%	Yes		Digital, Custom scale	Yes		Digital, 0-100% √ scale	Yes																		
Indicator	Arrester	Initial setting																																																																															
None	None																																																																																
Analog, 0-100% linear scale	None																																																																																
Analog, 0-100% √ scale	None	4-20mA DC																																																																															
Analog, Custom scale	None	+																																																																															
Analog, double scale	None	Hart ®/Fuji																																																																															
None	Yes	digital signal																																																																															
Analog, 0-100% linear scale	Yes	"SMART"																																																																															
Analog, 0-100% √ scale	Yes																																																																																
Analog, Custom scale	Yes																																																																																
Analog, double scale	Yes																																																																																
Digital, 0-100%	None																																																																																
Digital, Custom scale	None																																																																																
Digital, 0-100% √ scale	None																																																																																
Digital, 0-100%	Yes																																																																																
Digital, Custom scale	Yes																																																																																
Digital, 0-100% √ scale	Yes																																																																																
													<b>Approvals for hazardous locations (consult FUJI for availability)</b> None (Standard) ATEX - Flameproof enclosures (digit 4 = "M, P, R, T" & "W" only) ATEX - Intrinsic Safety FM - Explosion-Proof (digit 4 = "P" & "T" only) CSA - Explosion-Proof (digit 4 = "P" & "T" only) FM - Intrinsic Safety and Non Incendive CSA - Intrinsic Safety ATEX - Type "n" (digit 9 = A, E, 1, 2, 3, 4, 5 & 6 only) IECEX - Type "n" (digit 9 = A, E, 1, 2, 3, 4, 5 & 6 only) IECEX - Flameproof enclosures (digit 4 = "M, P, R, T" & "W" only) IECEX - Intrinsic Safety CSA - Explosion-Proof & Intrinsic Safety combined approval (digit 4 = "P" & "T" only) ATEX - Flameproof enclosures & Intrinsic Safety combined approval (digit 4 = "M, P, R, T" & "W" only) IECEX - Flameproof enclosures & Intrinsic Safety combined approval (digit 4 = "M, P, R, T" & "W" only) FM - Explosion-Proof & Intrinsic Safety combined approval (digit 4 = "P" & "T" only)																																																																				
													(*5) (*6) <b>Mounting design (*3)</b>																																																																				
													<b>Ambient temperature correction</b>																																																																				
													<table border="1"> <thead> <tr> <th>Operating pressure (bar)</th><th>Bolts/nuts</th><th>SS tag plate</th><th>SS housing</th></tr> </thead> <tbody> <tr> <td>p ≤ 50 bar</td><td>None</td><td>None</td><td>None</td></tr> <tr> <td>p ≤ 50 bar</td><td>None</td><td>Yes</td><td>None</td></tr> <tr> <td>p ≤ 50 bar</td><td>None</td><td>None</td><td>Yes</td></tr> <tr> <td>p ≤ 50 bar</td><td>None</td><td>Yes</td><td>Yes</td></tr> <tr> <td>50 &lt; p ≤ 160</td><td>Carbon steel</td><td>None</td><td>None</td></tr> <tr> <td>50 &lt; p ≤ 160</td><td>Carbon steel</td><td>Yes</td><td>None</td></tr> <tr> <td>50 &lt; p ≤ 160</td><td>Carbon steel</td><td>None</td><td>Yes</td></tr> <tr> <td>50 &lt; p ≤ 160</td><td>Carbon steel</td><td>Yes</td><td>Yes</td></tr> <tr> <td>p ≤ 160 bar</td><td>SS 316/SS 316</td><td>None</td><td>None</td></tr> <tr> <td>p ≤ 160 bar</td><td>SS 316/SS 316</td><td>Yes</td><td>None</td></tr> <tr> <td>p ≤ 160 bar</td><td>SS 316/SS 316</td><td>None</td><td>Yes</td></tr> <tr> <td>p ≤ 100 bar</td><td>SS 316/SS 316</td><td>Yes</td><td>Yes</td></tr> <tr> <td>p = 100 bar max</td><td>SS 660/SS 660</td><td>None</td><td>None</td></tr> <tr> <td>p = 100 bar max</td><td>SS 660/SS 660</td><td>Yes</td><td>None</td></tr> <tr> <td>p = 100 bar max</td><td>SS 660/SS 660</td><td>None</td><td>Yes</td></tr> <tr> <td>p = 100 bar max</td><td>SS 660/SS 660</td><td>Yes</td><td>Yes</td></tr> </tbody> </table>	Operating pressure (bar)	Bolts/nuts	SS tag plate	SS housing	p ≤ 50 bar	None	None	None	p ≤ 50 bar	None	Yes	None	p ≤ 50 bar	None	None	Yes	p ≤ 50 bar	None	Yes	Yes	50 < p ≤ 160	Carbon steel	None	None	50 < p ≤ 160	Carbon steel	Yes	None	50 < p ≤ 160	Carbon steel	None	Yes	50 < p ≤ 160	Carbon steel	Yes	Yes	p ≤ 160 bar	SS 316/SS 316	None	None	p ≤ 160 bar	SS 316/SS 316	Yes	None	p ≤ 160 bar	SS 316/SS 316	None	Yes	p ≤ 100 bar	SS 316/SS 316	Yes	Yes	p = 100 bar max	SS 660/SS 660	None	None	p = 100 bar max	SS 660/SS 660	Yes	None	p = 100 bar max	SS 660/SS 660	None	Yes	p = 100 bar max	SS 660/SS 660	Yes	Yes
Operating pressure (bar)	Bolts/nuts	SS tag plate	SS housing																																																																														
p ≤ 50 bar	None	None	None																																																																														
p ≤ 50 bar	None	Yes	None																																																																														
p ≤ 50 bar	None	None	Yes																																																																														
p ≤ 50 bar	None	Yes	Yes																																																																														
50 < p ≤ 160	Carbon steel	None	None																																																																														
50 < p ≤ 160	Carbon steel	Yes	None																																																																														
50 < p ≤ 160	Carbon steel	None	Yes																																																																														
50 < p ≤ 160	Carbon steel	Yes	Yes																																																																														
p ≤ 160 bar	SS 316/SS 316	None	None																																																																														
p ≤ 160 bar	SS 316/SS 316	Yes	None																																																																														
p ≤ 160 bar	SS 316/SS 316	None	Yes																																																																														
p ≤ 100 bar	SS 316/SS 316	Yes	Yes																																																																														
p = 100 bar max	SS 660/SS 660	None	None																																																																														
p = 100 bar max	SS 660/SS 660	Yes	None																																																																														
p = 100 bar max	SS 660/SS 660	None	Yes																																																																														
p = 100 bar max	SS 660/SS 660	Yes	Yes																																																																														
													<table border="1"> <thead> <tr> <th>Operating pressure (bar)</th><th>Bolts/nuts</th><th>SS tag plate</th><th>SS housing</th></tr> </thead> <tbody> <tr> <td>p ≤ 50 bar</td><td>None</td><td>None</td><td>None</td></tr> <tr> <td>p ≤ 50 bar</td><td>None</td><td>Yes</td><td>None</td></tr> <tr> <td>p ≤ 50 bar</td><td>None</td><td>None</td><td>Yes</td></tr> <tr> <td>p ≤ 50 bar</td><td>None</td><td>Yes</td><td>Yes</td></tr> <tr> <td>50 &lt; p ≤ 160</td><td>Carbon steel</td><td>None</td><td>None</td></tr> <tr> <td>50 &lt; p ≤ 160</td><td>Carbon steel</td><td>Yes</td><td>None</td></tr> <tr> <td>50 &lt; p ≤ 160</td><td>Carbon steel</td><td>None</td><td>Yes</td></tr> <tr> <td>50 &lt; p ≤ 160</td><td>Carbon steel</td><td>Yes</td><td>Yes</td></tr> <tr> <td>p ≤ 160 bar</td><td>SS 316/SS 316</td><td>None</td><td>None</td></tr> <tr> <td>p ≤ 160 bar</td><td>SS 316/SS 316</td><td>Yes</td><td>None</td></tr> <tr> <td>p ≤ 160 bar</td><td>SS 316/SS 316</td><td>None</td><td>Yes</td></tr> <tr> <td>p ≤ 100 bar</td><td>SS 316/SS 316</td><td>Yes</td><td>Yes</td></tr> <tr> <td>p = 100 bar max</td><td>SS 660/SS 660</td><td>None</td><td>None</td></tr> <tr> <td>p = 100 bar max</td><td>SS 660/SS 660</td><td>Yes</td><td>None</td></tr> <tr> <td>p = 100 bar max</td><td>SS 660/SS 660</td><td>None</td><td>Yes</td></tr> <tr> <td>p = 100 bar max</td><td>SS 660/SS 660</td><td>Yes</td><td>Yes</td></tr> </tbody> </table>	Operating pressure (bar)	Bolts/nuts	SS tag plate	SS housing	p ≤ 50 bar	None	None	None	p ≤ 50 bar	None	Yes	None	p ≤ 50 bar	None	None	Yes	p ≤ 50 bar	None	Yes	Yes	50 < p ≤ 160	Carbon steel	None	None	50 < p ≤ 160	Carbon steel	Yes	None	50 < p ≤ 160	Carbon steel	None	Yes	50 < p ≤ 160	Carbon steel	Yes	Yes	p ≤ 160 bar	SS 316/SS 316	None	None	p ≤ 160 bar	SS 316/SS 316	Yes	None	p ≤ 160 bar	SS 316/SS 316	None	Yes	p ≤ 100 bar	SS 316/SS 316	Yes	Yes	p = 100 bar max	SS 660/SS 660	None	None	p = 100 bar max	SS 660/SS 660	Yes	None	p = 100 bar max	SS 660/SS 660	None	Yes	p = 100 bar max	SS 660/SS 660	Yes	Yes
Operating pressure (bar)	Bolts/nuts	SS tag plate	SS housing																																																																														
p ≤ 50 bar	None	None	None																																																																														
p ≤ 50 bar	None	Yes	None																																																																														
p ≤ 50 bar	None	None	Yes																																																																														
p ≤ 50 bar	None	Yes	Yes																																																																														
50 < p ≤ 160	Carbon steel	None	None																																																																														
50 < p ≤ 160	Carbon steel	Yes	None																																																																														
50 < p ≤ 160	Carbon steel	None	Yes																																																																														
50 < p ≤ 160	Carbon steel	Yes	Yes																																																																														
p ≤ 160 bar	SS 316/SS 316	None	None																																																																														
p ≤ 160 bar	SS 316/SS 316	Yes	None																																																																														
p ≤ 160 bar	SS 316/SS 316	None	Yes																																																																														
p ≤ 100 bar	SS 316/SS 316	Yes	Yes																																																																														
p = 100 bar max	SS 660/SS 660	None	None																																																																														
p = 100 bar max	SS 660/SS 660	Yes	None																																																																														
p = 100 bar max	SS 660/SS 660	None	Yes																																																																														
p = 100 bar max	SS 660/SS 660	Yes	Yes																																																																														

Notes\* :

- 1- Turn down of 100:1 is possible, but should be used at the span greater than 1/10 of the maximum span for better performance
- 2- For DN = 50 consult FUJI for your application with the specific operating conditions
- 3- Transmitter with capillary design has a standard mounting bracket
- 4- If direct mounted seal design is required, bolts are necessary even when p < 50bar
- 5- Standard fill fluid of measuring cells : silicone oil - Others fill fluids : upon request
- 6- Transmitter with different diaphragm seals or capillary lengths on HP and LP side must be temperature corrected.
- 7- Code "D & V" FM approval only possible with electrical connection 1/2"-14 NPT.
- 8- Our stainless steel bolts/nuts in SS 660 are in conformity with the NACE requirements and must be used for NACE service

# CODE SYMBOLS - FKM

1	2	3	4	5	6	7	8	9	10	11	12	13	DESCRIPTION																																												
F	K	M			V	F	-																																																		
																		<b>Type</b> Smart, 4-20 mAdc + Fuji/Hart® digital signal																																							
																		<b>Conduit connection</b> 1/2"-14NPT Pg 13.5 M20 x 1.5																																							
																		<b>Diaphragm seal rating</b> PN 25 PN 20 - 150 Lbs PN 50 - 300 Lbs PN 40 PN 16																																							
																		(*1) <b>Spans</b> (*2) 0 to 0.016/0.16 bar abs (*3) 0 to 0.013/1.3 bar abs 0 to 0.05/5 bar abs 0 to 0.3/30 bar abs 0 to 1/100 bar abs																																							
																		<b>Indicator, arrester and initial setting</b>																																							
																		<table border="1"> <thead> <tr> <th>Indicator</th><th>Arrester</th><th>Initial setting</th></tr> </thead> <tbody> <tr><td>None</td><td>None</td><td></td></tr> <tr><td>Analog, 0-100% linear scale</td><td>None</td><td></td></tr> <tr><td>Analog, Custom scale</td><td>None</td><td></td></tr> <tr><td>Analog, double scale</td><td>None</td><td>4-20mA DC</td></tr> <tr><td>None</td><td>Yes</td><td>+</td></tr> <tr><td>Analog, 0-100% linear scale</td><td>Yes</td><td>Hart®/Fuji</td></tr> <tr><td>Analog, Custom scale</td><td>Yes</td><td>digital signal</td></tr> <tr><td>Analog, double scale</td><td>Yes</td><td>'SMART'</td></tr> <tr><td>Digital, 0-100%</td><td>None</td><td></td></tr> <tr><td>Digital, Custom scale</td><td>None</td><td></td></tr> <tr><td>Digital, 0-100%</td><td>Yes</td><td></td></tr> <tr><td>Digital, Custom scale</td><td>Yes</td><td></td></tr> </tbody> </table>	Indicator	Arrester	Initial setting	None	None		Analog, 0-100% linear scale	None		Analog, Custom scale	None		Analog, double scale	None	4-20mA DC	None	Yes	+	Analog, 0-100% linear scale	Yes	Hart®/Fuji	Analog, Custom scale	Yes	digital signal	Analog, double scale	Yes	'SMART'	Digital, 0-100%	None		Digital, Custom scale	None		Digital, 0-100%	Yes		Digital, Custom scale	Yes	
Indicator	Arrester	Initial setting																																																							
None	None																																																								
Analog, 0-100% linear scale	None																																																								
Analog, Custom scale	None																																																								
Analog, double scale	None	4-20mA DC																																																							
None	Yes	+																																																							
Analog, 0-100% linear scale	Yes	Hart®/Fuji																																																							
Analog, Custom scale	Yes	digital signal																																																							
Analog, double scale	Yes	'SMART'																																																							
Digital, 0-100%	None																																																								
Digital, Custom scale	None																																																								
Digital, 0-100%	Yes																																																								
Digital, Custom scale	Yes																																																								
																		<b>Approvals for hazardous locations (consult FUJI for availability)</b>																																							
																		None (Standard)																																							
																		ATEX - Flameproof enclosures (digit 4 = "M, P, R, T" & "W" only)																																							
																		ATEX - Intrinsic Safety																																							
																		(*7) FM - Explosion-Proof (digit 4 = "P" & "T" only)																																							
																		CSA - Explosion-Proof (digit 4 = "P" & "T" only)																																							
																		FM - Intrinsic Safety and Non Incendive																																							
																		CSA - Intrinsic Safety																																							
																		ATEX - Type "n" (digit 9 = A, E, 1, 2, 3, 4, 5 & 6 only)																																							
																		IECEX - Type "n" (digit 9 = A, E, 1, 2, 3, 4, 5 & 6 only)																																							
																		IECEX - Flameproof enclosures (digit 4 = "M, P, R, T" & "W" only)																																							
																		IECEX - Intrinsic Safety																																							
																		CSA - Explosion-Proof & Intrinsic Safety combined approval (digit 4 = "P" & "T" only)																																							
																		ATEX - Flameproof enclosures & Intrinsic Safety combined approval (digit 4 = "M, P, R, T" & "W" only)																																							
																		IECEX - Flameproof enclosures & Intrinsic Safety combined approval (digit 4 = "M, P, R, T" & "W" only)																																							
																		FM - Explosion-Proof & Intrinsic Safety combined approval (digit 4 = "P" & "T" only)																																							
																		<b>Mounting design (*4)</b>																																							
																		<b>Ambient temperature correction</b>																																							
																		Capillary																																							
																		Rigid - long design																																							
																		Rigid - short design																																							
																		Capillary																																							
																		Rigid - long design																																							
																		Rigid - short design																																							
																		<b>Stainless steel parts</b>																																							
																		<b>Bolts/nuts</b>																																							
																		<b>SS tag plate</b>																																							
																		<b>SS housing &amp; mounting bracket</b>																																							
																		1 Y (*6) (*5) None (capillary mounting)																																							
																		2 Y (*6) (*5) None (capillary mounting)																																							
																		3 Y (*6) (*5) None (capillary mounting)																																							
																		4 Y (*6) (*5) None (capillary mounting)																																							
																		Y Y (*6) Carbon steel																																							
																		B Y (*6) Carbon steel																																							
																		C Y (*6) Carbon steel																																							
																		E Y (*6) Carbon steel																																							
																		A Y (*6) SS 316/SS 316																																							
																		D Y (*6) SS 316/SS 316																																							
																		F Y (*6) SS 316/SS 316																																							
																		G Y (*6) SS 316/SS 316																																							
																		H Y (*6) (*8) SS 660/SS 660																																							
																		J Y (*6) (*8) SS 660/SS 660																																							
																		K Y (*6) (*8) SS 660/SS 660																																							
																		L Y (*6) (*8) SS 660/SS 660																																							

**Notes\* :**

- 1- Turn down of 100:1 is possible, but should be used at the span greater than 1/10 of the maximum span for better performance.
- 2- Consult FUJI for your application with the specific operating conditions
- 3- For DN = 50 consult FUJI for your application with the specific operating conditions
- 4- Transmitter with capillary design has a standard mounting bracket - rigid mounting design are always without mounting bracket
- 5- Flange rating according max. operating pressure - for DN < 50 flange size and / or PN > 150 - consult FUJI
- 6- Standard fill fluid of measuring cells : silicone oil - other fill fluids : upon request
- 7- Code "D & V" FM approval only possible with electrical connection 1/2"-14 NPT
- 8- Our stainless steel bolts/nuts in SS 660 are in conformity with the NACE requirements and must be used for NACE service.

# DIAPHRAGM SEAL(S)

Diaphragm seals are used to measure accurately liquid level, density on open and closed tanks, or flow measurement in pipes. The use of the diaphragm seal(s) avoid(s) that the measuring cell is directly in contact with the process. The welded seal construction assures excellent reliability in high temperature and high corrosive, viscous, sticking, crystallizable and abrasive process conditions.

## FEATURES

### 1- Construction

The diaphragm seals are mounted on differential, gauge and absolute pressure transmitters of FCX-All series. The seal can be rigid, (direct) mounted on the transmitter or with capillaries between the seal and the transmitter.

The construction is an all welded design without any gasket between the seal and the transmitter diaphragm and is filled with the suitable oil for your application.

### 2- Operating principle

The measuring pressure is applied on the diaphragm seal and transferred by the filling fluid through the capillary tube to the measuring cell of the pressure transmitter.

### 3- Parts materials

Wetted parts materials (diaphragm and gasket face) are in stainless steel, Tantalum, Hastelloy, Monel, Titanium, Zirconium, Nickel, depending on the application requirements. Other parts are in stainless steel: capillary tube, reduced volume flange, diaphragm seal body, direct mounting connection parts.

Standard filling fluid is silicone oil. Fluorinated oil, sanitary oil, high temperature oil and vacuum service filling are available through model selection.

### 4- Diaphragm seal types

According to the mounting and operating conditions different seal types can be useful :

Flush mounting design from DN40 to DN100.

Seals with extensions (50 to 200 mm).

Flanged, screwed or weld neck adaptors

Seals for sanitary applications according DIN, SMS or Tri-Clamp standards



## SPECIFICATIONS

### Functional specifications

#### Diaphragm seal application :

The seal(s) can be mounted direct or rigid on the transmitter (for example for liquid level measurement at the bottom of the tank) or capillary mounted to distance the measuring point away from the transmitter (for example in case of high process temperature). The rigid mounted seal can be assembled in a long design or in a short (compact) design according to the physical dimension requests of the customer (see outline dimensions drawings).

	Rigid mounting	Capillary mounting
F#B	short or long design	HP side
F#M	short or long design	HP side
F#D	see datasheet of level transmitter	HP and LP side HP side LP side

#### Capillary tube specifications :

Standard capillary lengths :

1,5 / 3 / 6 m (other upon request)

Inside diameter :

1 mm standard

2 mm for vacuum service, high process temperature applications, short response time requirements

Smallest bending radius of the capillary : 100 mm

#### Capillary tube sheald possibilities :

PVC sheald :

Temperature limit : -10 à 80°C

Stainless steel sheald :

Temperature limit : -40 à 400°C

#### Temperature limits :

Ambiant temperature : -40 to 85°C

Process temperature :

-40 to 150°C for rigid mounting,

-40 to 400°C for capillary design, and according the filling fluid limitations.



**Pressure limits :**

Working pressure :

Limited by the static pressure or the working pressure of the transmitter or by the nominal flange rating of the diaphragm seal (PN). (Please take the smallest of both)

Vacuum limit :

Depending of the limit of the transmitter and the filling fluid of the seal.

For a differential or gauge pressure transmitter the lowest vacuum is 20 Torr or 27 mbar abs.

Only the absolute pressure transmitter can be used till absolute zero (FKM).

For the utilization of vacuum service < 20 Torr (27 mbar abs.) the absolute pressure transmitter has to be used.

**Process temperature effect : (mbar/10°C)**

Seals	DN 50 / 2" SS diaphragm	DN 80 / 3" SS diaphragm	DN 80 / 3" Other diaph. materials.	DN 100 / 4" SS diaphragm	Adaptor SS diaphragm
for transmitters					
FKB/FKM	1.24	0.17	0.73	0.08	0.17
FKD	0.5	0.09	0.22	0.05	0.09

**Note : the indicated values are in mbar/10°C**

**Static pressure effect for ΔP transmitter with stainless steel diaphragms (F#D transmitter with DN80 and DN100 seals) :**

Zero shift :

± 0,2% of URL for flange rating, up to 40 bar or 300 lbs

Span shift :

- 0,2% <sup>+0,2%</sup>

- 0,1% of calibrated span for flange rating pressure

**Response time : (mean values)**

Oil filling	Code digit 7	Density at 25°C	Response time	
			0 to 320 mbar	0 to 1.3 bar
Std silicone oil	Y, G	0,95	0,15	0,037
Fluorinated oil	W,A,D	1,84	0,17	0,04
Oil for vacuum or high temperature	V, T	1,07	0,25	0,065

The indicated values are in seconds per meter of capillary length with internal tube diameter Ø 1 mm.

The indicated response time is based on a pressure change of 0 to 100% of the calibrated span at reference temperature of 20°C. The indicated values do not include the response time of the transmitter.

**Filling fluid of the diaphragm seals :**

Code digit 7	Designation	Temperature resistance (°C)		Density (25°C)
		P abs ≥ 1 bar	P abs < 1 bar	
Y	Silicone oil	-40 to 180	-40 to 120	0,95
W	Fluorinated oil	-20 to 200	-20 to 120	1,84
F	Sanitary fill fluids	-10 to 250	-10 to 120	0,92
V	Silicone oil		20 to 200	1,07
T	Silicone oil	20 to 350	20 to 200	1,07

The indicated values and limits are indicated for the most common applications (standard filling fluids).

Please ask Fuji Electric for special applications indicating your temperature, pressure and vacuum conditions (vacuum and temperature can occur together).

Other filling fluids can be used for your applications.

**Performance specifications**

To calculate the total performance, both the transmitter and the diaphragm seals performances have to be added.

**Accuracy : (at reference conditions)**

The assembling of 1 or 2 diaphragm seals on a transmitter increases the accuracy error at reference conditions of 0,1% of the span.

**Ambient temperature effect :**

*Effect when transmitter alone is corrected*

Seal	DN 50 / 2" SS diaphr.	DN 80 / 3" SS diaphr.	DN 80 / 3" other diaph. materials	DN 100 / 4" SS diaphr.	Adaptor SS diaphr.
Transmitters					
FKB/FKM - gauge /abs pressure	2.03	0.11	0.22	0.04	0.11
capillary(m)	1.5	0.08	0.2	0.03	0.08
FKD - differential pressure	0.48	0.04	0.05	0.02	0.04
capillary (m)	0.32	0.03	0.07	0.01	0.03

**Note : the indicated values are in mbar/10°C for capillary length of 1m and internal capillary tube ø of 1 mm**

Effect when transmitter and the seal assembly is corrected

The zero drift due to ambient temperature changes are improved (between 2 and 5 times) by an additional temperature correction operation of the complete transmitter unit (transmitter and seals) (see code B,C,L,M digit 11 of the codification FKB, FKD, FKM)

A thermal isolation or a heating of the capillaries minimises the ambient temperature effect.

CODE SYMBOLS - S

1	2	3	4	5	6	7	8	DESCRIPTION
S								Flanged axial diaphragm seal connection
A								Flanged radial diaphragm seal connection - Not possible with rigid mounting design digit 6 : code R
R								Wafer type - Not possible with rigid mounting design digit 6 : code R
W								
								(*1) Flanges RF (Flange size and rating)
4								ANSI-150LB 3"-ISO PN 20 DN 80
5								ANSI-150LB 4"-ISO PN 20 DN 100
6								ANSI-300LB 3"-ISO PN 50 DN 80
7								ANSI-300LB 4"-ISO PN 50 DN 100
8								DIN PN40 DN80
9								DIN PN16 DN100
H								(*2) ANSI-150LB 2"-ISO PN 20 DN 50
J								(*2) ANSI-300LB 2"-ISO PN 50 DN 50
G								(*2) DIN PN40 DN50
U								PN 25 / DN 50 - coupling nut      DIN 11851 design      material code "V" only
V								PN 40 / DN 50 - coupling nut      SMS      material code "V" only
W								PN 40 / DN 50 - seal only      Clamp      material code "V" only
X								No dead volume      Sanitary      material code "V" only
A								(*3) Flange adaptor PN 40 DN 25      material code "V" - others UR
B								(*3) Flange adaptor ISO PN 20 DN 25 (1"-150 ANSI)      material code "V" - others UR
C								(*3) Flange adaptor ISO PN 50 DN 25 (1"- 300 ANSI)      material code "V" - others UR
D								(*3) Flange adaptor PN 40 DN 40      material code "V" - others UR
E								(*3) Flange adaptor ISO PN 20 DN 40 (1"1/2 - 150 ANSI)      material code "V" - others UR
F								(*3) Flange adaptor ISO PN 50 DN 40 (1"1/2 - 300 ANSI)      material code "V" - others UR
S								(*3) Screwed 1/2 NPT E      material code "V" - others UR
T								(*3) To be welded (pipe 2"1/2)      material code "V" - others UR
								<b>Diaphragm seal material</b>
V								Diaphragm      Flange raised face      Flange
H								(*4) SS 316 L      SS 316 L      SS 316 L
B								Hastelloy-C      Hastelloy-C      SS 316 L
T								Monel      Monel      SS 316 L
P								Tantalum      Tantalum      SS 316 L
R								(*9) Titanium      Titanium      SS 316 L
C								(*9) Zirconium      Zirconium      SS 316 L
K								SS 316 L + gold coat      SS 316 L      SS 316 L
F								(*10) SS 316 L + glued PTFE diaphragm      SS 316 L + PTFE      SS 316 L
								(*5) SS 316L + FEP lining      SS 316 L + FEP lining      SS 316 L
								<b>Diaphragm seal design</b>
Y								Flush mounting
A								(*6) Diaphragm extension 50 mm
B								(*6) Diaphragm extension 100 mm      material code "V" - digit 4
C								(*6) Diaphragm extension 150 mm
D								(*6) Diaphragm extension 200 mm
E								(*6) Diaphragm extension 50 mm
F								(*6) Diaphragm extension 100 mm      material code "H" - digit 4
G								(*6) Diaphragm extension 150 mm
H								(*6) Diaphragm extension 200 mm
J								(*6) Diaphragm extension 50 mm
K								(*6) Diaphragm extension 100 mm      material code "B" - digit 4
L								(*6) Diaphragm extension 150 mm
M								(*6) Diaphragm extension 200 mm
P								(*6) Diaphragm extension 50 mm
R								(*6) Diaphragm extension 100 mm      material code "T" - digit 4
S								(*6) Diaphragm extension 150 mm
T								(*6) Diaphragm extension 200 mm
								<b>Transmission diaphragm seal to measuring cell</b>
A								Mounting design      Capillary length      Capillary design
B								Capillary      1,5 m      PVC protection
C								Capillary      3 m      PVC protection
D								Capillary      6 m      PVC protection
G								Capillary      Upon request      PVC protection
H								(*7) Capillary      1,5 m      SS sheald
K								(*7) Capillary      3 m      SS sheald
L								(*7) Capillary      6 m      SS sheald
R								(*7) Capillary      Upon request      SS sheald
								Rigid design - not possible with digit 2 = R, W - max. process temperature : 150°C
								<b>Special applications and fill fluid for the diaphragm seal only</b>
Y								Treatment      Fill fluid
W								None (standard)      Silicone oil
F								None (standard)      Fluorinated oil
D								None (standard)      Sanitary fill fluid
G								Chlorine service      Fluorinated oil
A								Degreasing      Silicone oil
N								Oxygen service      Fluorinated oil
V								NACE      material code "V" only
T								(*8) Vacuum - max temperature 200°C      Silicone oil
								(*8) Very high temperature (20 to 350°C) - No vacuum

Notes :

- 1\* Different flange machinings (recess, groove, ...) upon request, standard flange machining = stock finish; except for digit 4 - material code H, B, T, P, R, F = smooth finish
- 2\* Only available with span higher than : 0 to 0,5/5 bar - max process temperature : 150°C - or ask FUJI with operating conditions
- 3\* Axial diaphragm seal connection - no extension possible
- 4\* SS316L for DN 50, 80 & 100 & flange adaptors
- 5\* Not possible with digit 7 : V, H, T
- 6\* All wetted parts in the same material (diaphragm, extension, flange gasket area) : - Other flange designs are available - only available with flange size digit 3 code 4, 5, 6, 7, 8, 9, H, J, G
- 7\* Recommended for Vacuum or High Temperature applications T > 120°C - (Capillary internal diameter = 2mm)
- 8\* Consult FUJI for your application with the specific operating conditions
- 9\* Max process temperature 150 °C
- 10\* Process temperature limit 260°C if no vacuum and 180°C if vacuum

# Outline dimensions for rigid mounted diaphragm seal on a gauge or an absolute pressure transmitter (unit:mm)

Dimensions of seals - Refer to page 18, 19 and 20

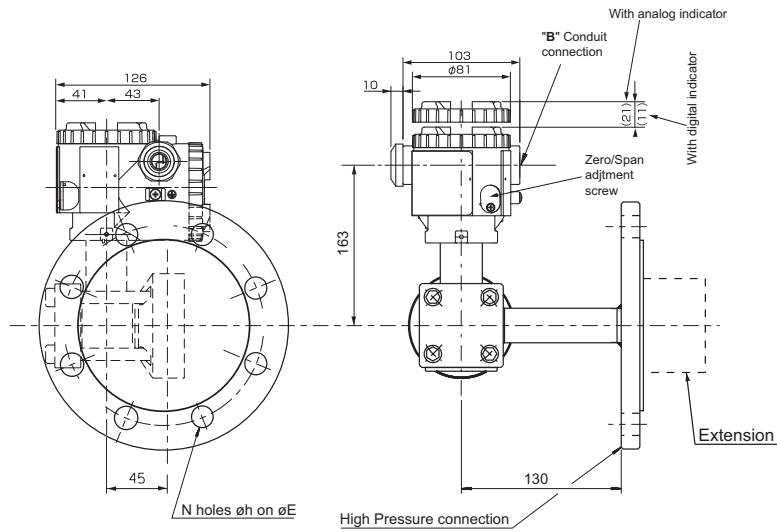

Short mounting design

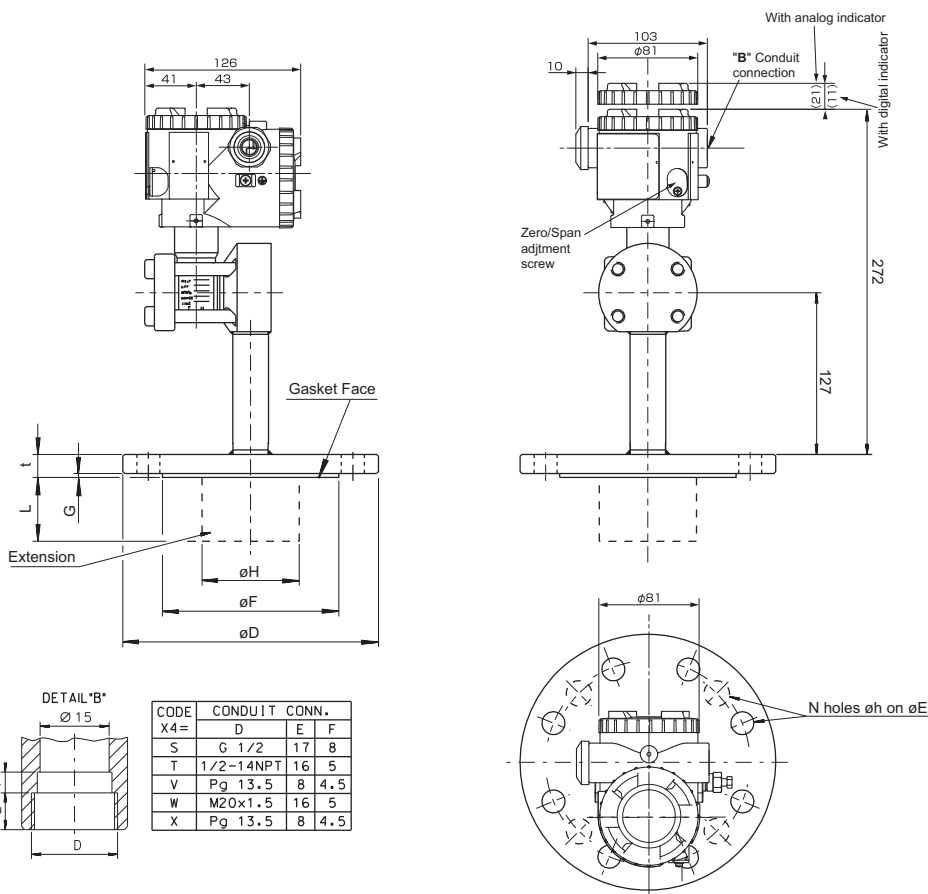
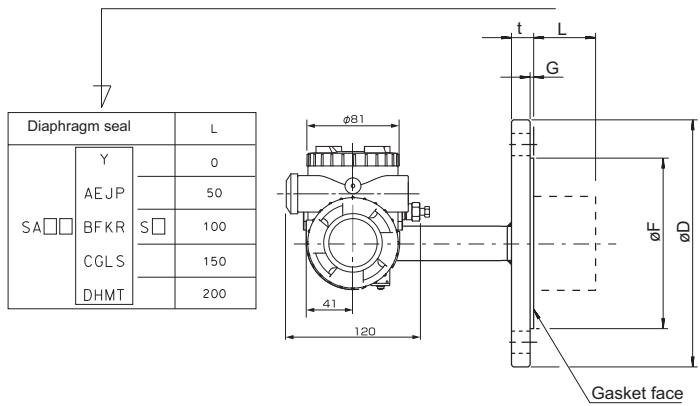

Long mounting design

# Outline dimensions for capillary mounted diaphragm seal(s) on a differential pressure transmitter (units:mm)

Dimensions of seals - Refer to page 18, 19 and 20

**For PN≤50bar : reduced volume flanges are welded on the measuring cell**

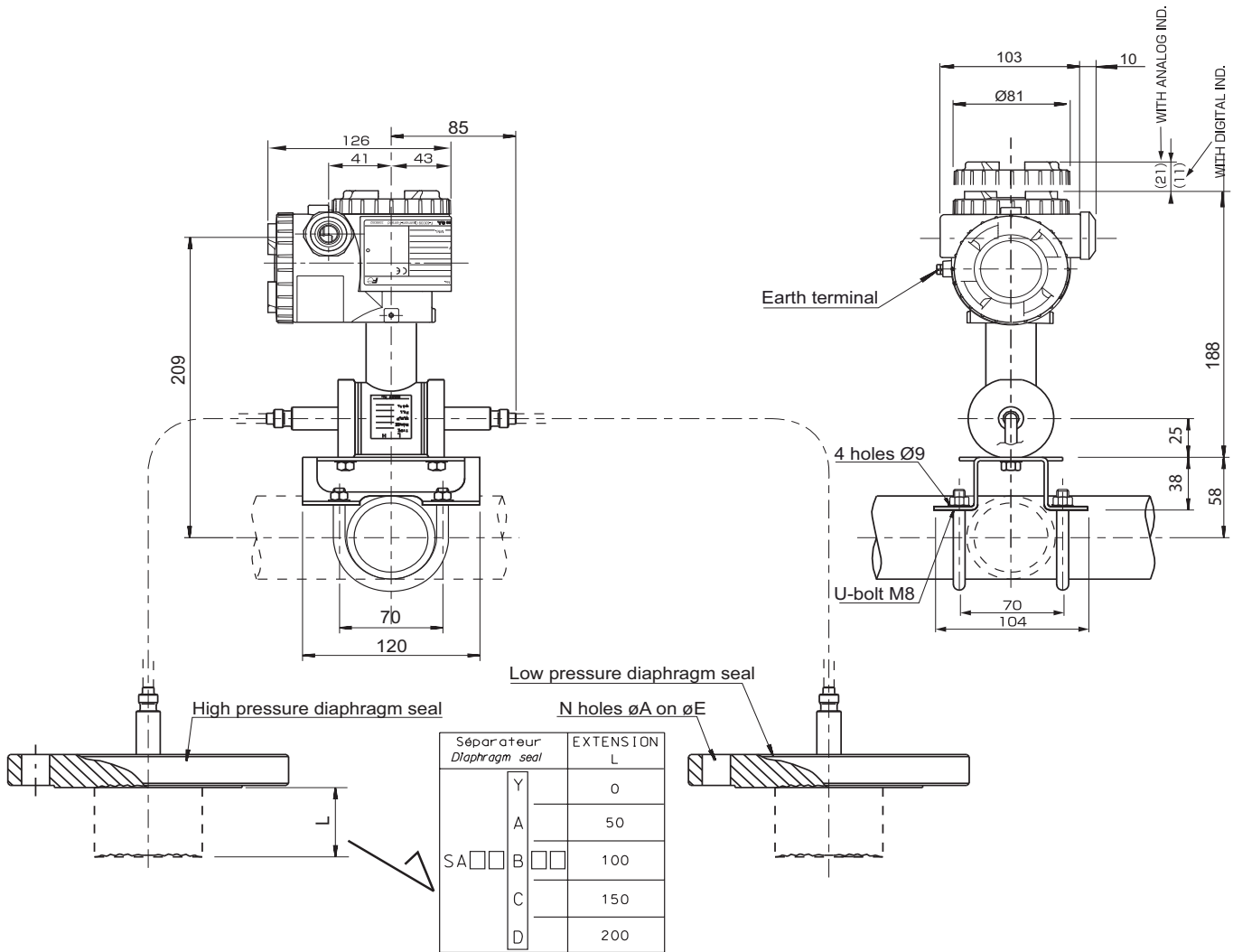

**For PN>50bar : reduced volume flanges are welded and bolted on the measuring cell**

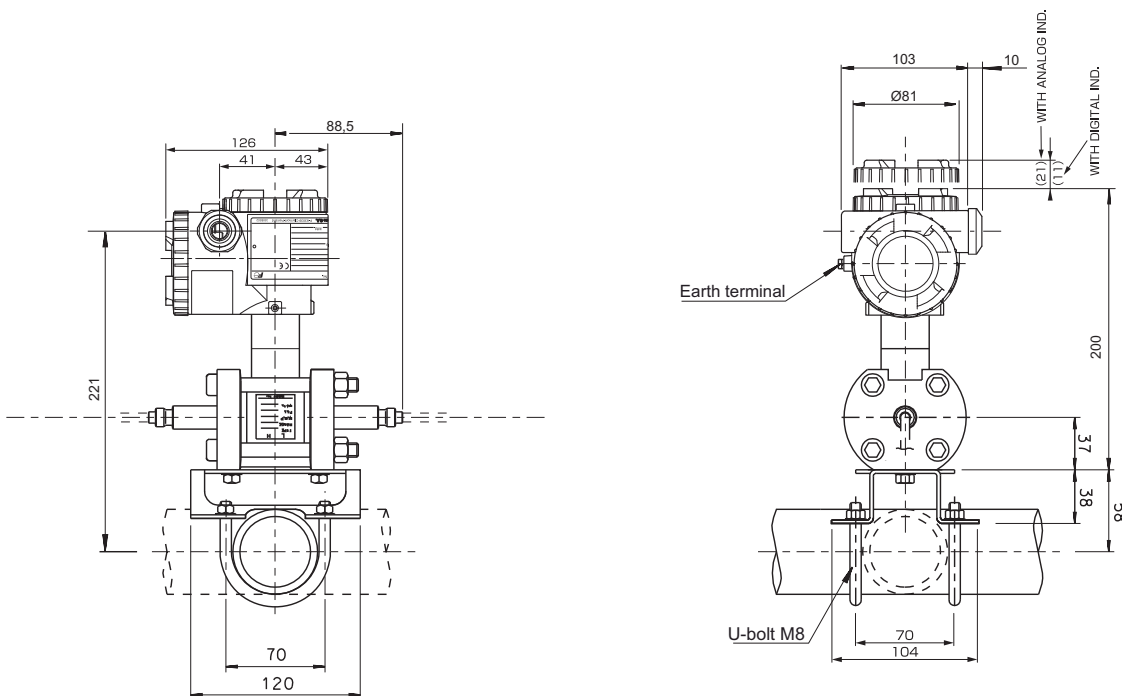

# Outline dimensions for capillary mounted diaphragm seal(s) on a gauge or an absolute pressure transmitter (units:mm)

Dimensions of seals - Refer to page 18, 19 and 20

**For PN≤50bar : reduced volume flanges are welded on the measuring cell**

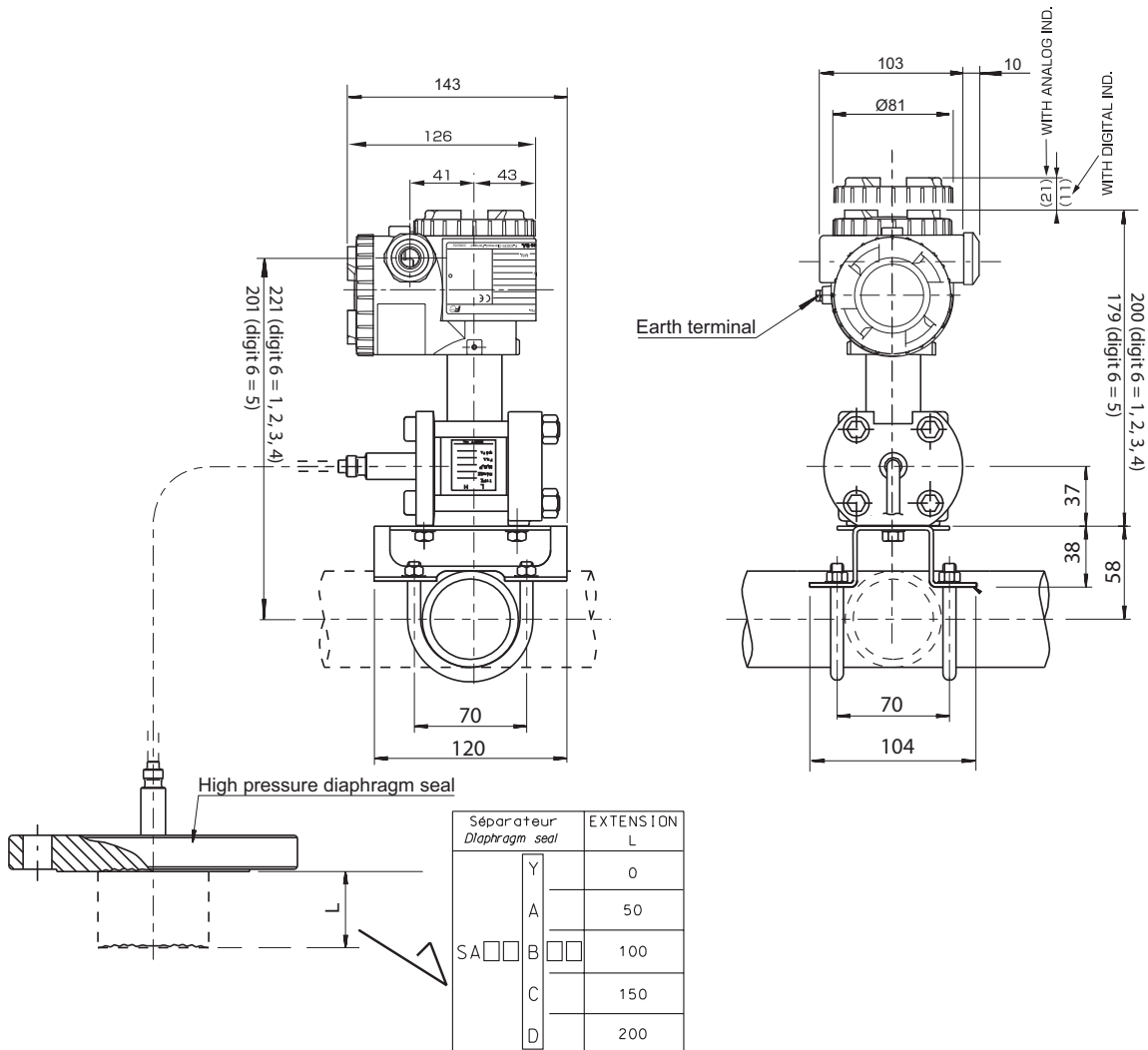

**For PN>50bar : reduced volume flanges are welded and bolted on the measuring cell**

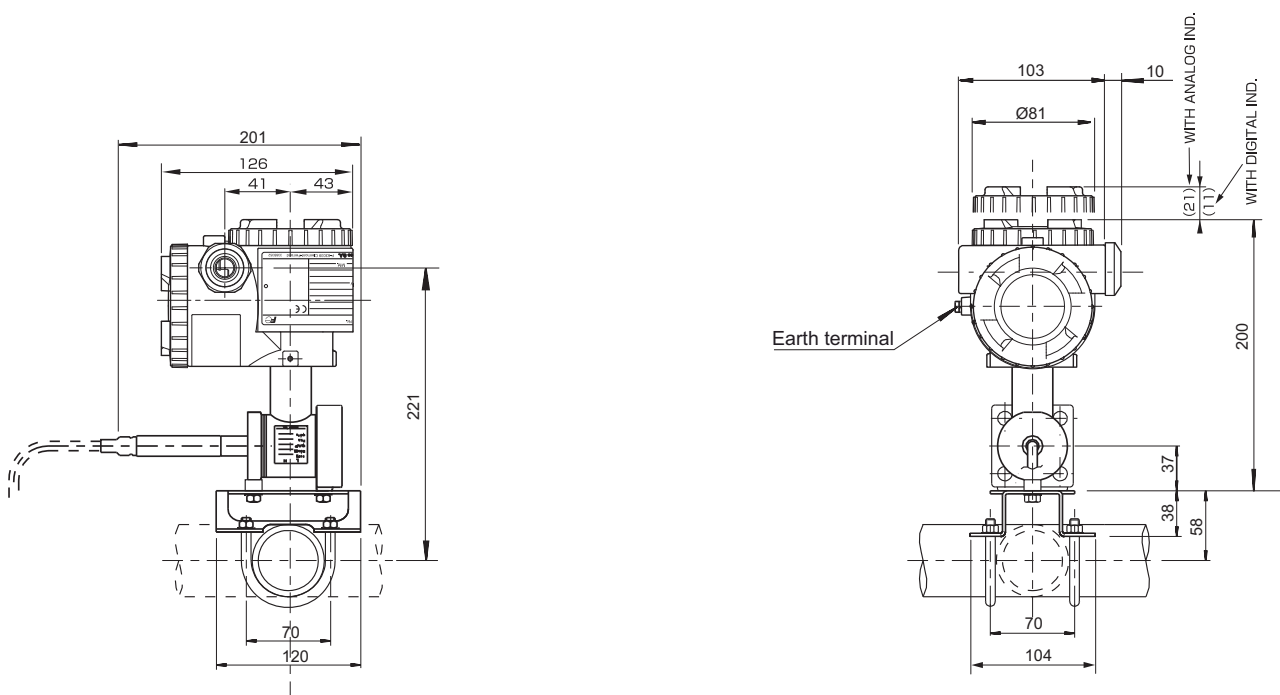

**Outline dimensions of the standard diaphragm seals - Flush and extension**

(units : mm)

DN 50, 80, 100

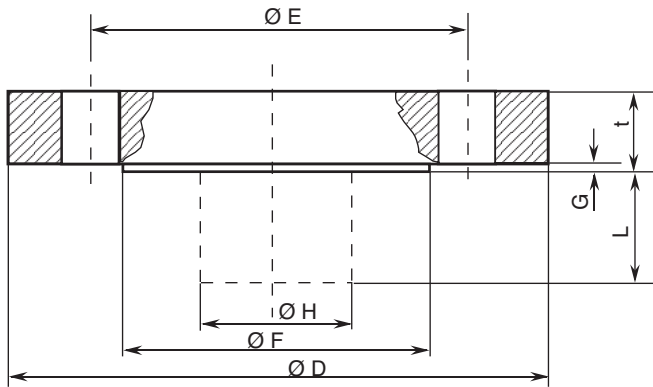

DN ≤ 25 or 1"

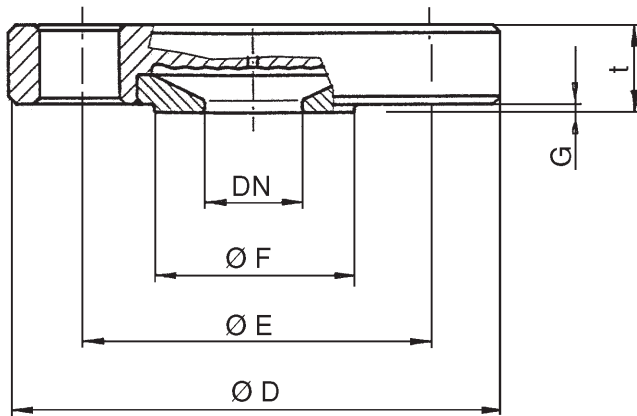

FLANGE DIMENSIONS ACCORDING DIN 2501 ET B16.5

DIN / ISO		ANSI		ØD	ØE	ØF	G	ØH	t	N x Øh
PN	DN	NP	NW							
40	15			95	65	45	2		22	4 x 14
40	20			105	75	58	2		22	4 x 14
40	25			115	85	68	2		22	4 x 14
40	50			165	125	102	3	48	20	4 x 18
40	80			200	160	138	3	73	20	8 x 18
16	100			220	180	158	3	96	20	8 x 18
20	15	150 lbs	1/2"	95	60,5	35	2		22	4 x 16
20	20	150 lbs	3/4"	100	70	43	2		22	4 x 16
20	25	150 lbs	1"	110	79,5	51	2		22	4 x 16
50	15	300 lbs	1/2"	95	66,5	35	2		22	4 x 16
50	20	300 lbs	3/4"	120	82,5	43	2		22	4 x 20
50	25	300 lbs	1"	125	89	51	2		22	4 x 20
20	50	150 lbs	2"	150	120,5	92	1,6	48	20	4 x 20
20	80	150 lbs	3"	190	152,5	127	1,6	73	24	4 x 20
20	100	150 lbs	4"	230	190,5	158	1,6	96	24	8 x 20
50	50	300 lbs	2"	165	127	92	1,6	48	22,5	8 x 20
50	80	300 lbs	3"	210	168,5	127	1,6	73	29	8 x 22
50	100	300 lbs	4"	255	200	158	1,6	96	32	8 x 22

**Outline dimensions of diaphragm seals with adaptors (units : mm)**

Flange adaptor

Screwed adaptor

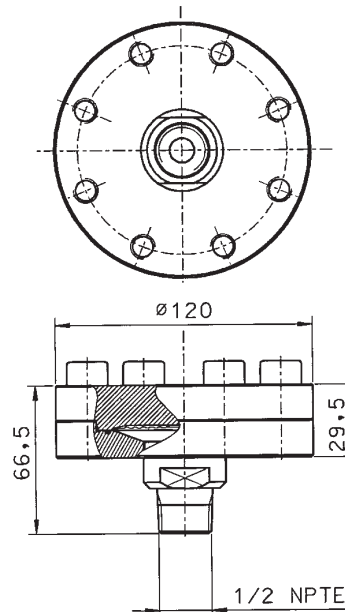
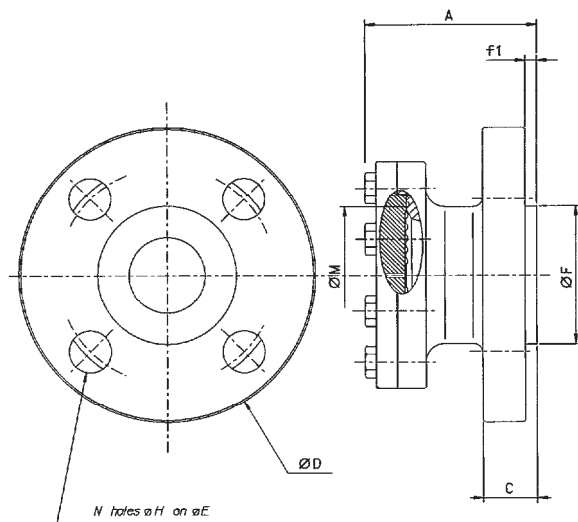

FLANGES DIMENSIONS												
DIN		ANSI		ØD	ØE			ØF	Cmin	f1	A	ØM
PN	DN	Pe	DN			N	ØH					
40	25			115	85	4	14	68	17	2	83	72,2
20	25	150	1"	108	79,5	4	15,8	50,8	16	1,6	81	72,2
50	25	300	1"	124	88,9	4	19	50,8	17,5	1,6	86	72,2
40	40			150	110	4	18	88	17	3	85	72,2
20	40	150	1 1/2"	127	98,4	4	15,8	73	17,5	16	85	72,2
50	40	300	1 1/2"	156	114,3	4	22,2	20,6	73	1,6	91	72,2

# Outline dimensions of sanitary diaphragm (units : mm)

The seals for the sanitary and pharmaceutical applications are available DIN, SMS and Tri Clamp standards

## Seals according DIN 11851 and SMS standard

2 different designs exists for DIN 11851 and SMS : ( $d_M$  = diamètre actif de la membrane)

**Coupling nut design**

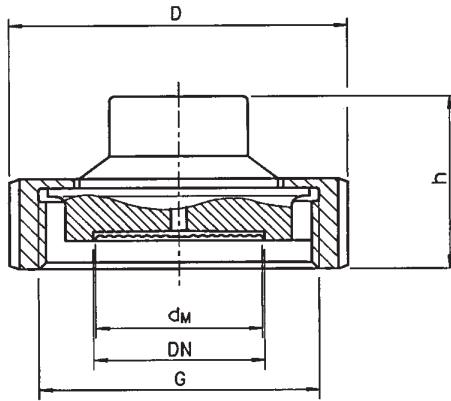

DIN 11851					
DN	PN (Max)	D	h	$d_M$	G
25	40	63	36	25	Rd 52 x 1/6
32	40	70	36	32	Rd 58 x 1/6
40	40	78	36	40	Rd 65 x 1/6
50	40	112	36	52	Rd 78 x 1/6
65	40	112	36	65	Rd 95 x 1/6
80	40	127	36	76	Rd110 x 1/4

**Male thread design**

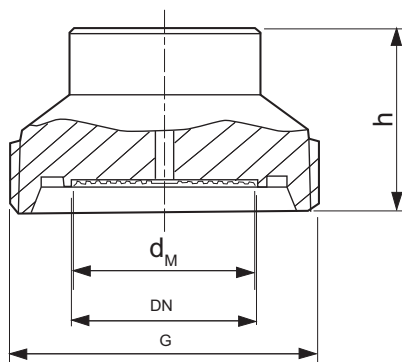

SMS					
DN	PN (Max)	D	h	$d_M$	G
25	40	51	38	25	Rd 40 x 1/6
32	40	60	38	32	Rd 48 x 1/6
38	40	74	38	40	Rd 60 x 1/6
51	40	84	38	52	Rd 70 x 1/6
63.5	40	100	38	65	Rd 85 x 1/6
76	40	114	38	76	Rd 98 x 1/4

**Tri Clamp design**

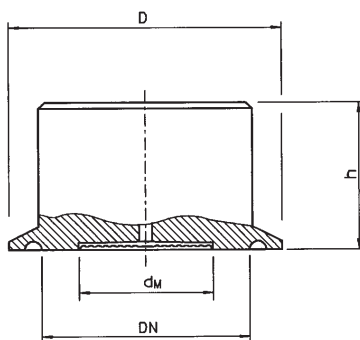

DN	PN (Max)	D	h	$d_M$
1"1/2	40	50,5	35	32
2"	40	64	35	40
2"1/2	40	77,5	35	50
3"	40	91	35	65

**Dead volume seal**

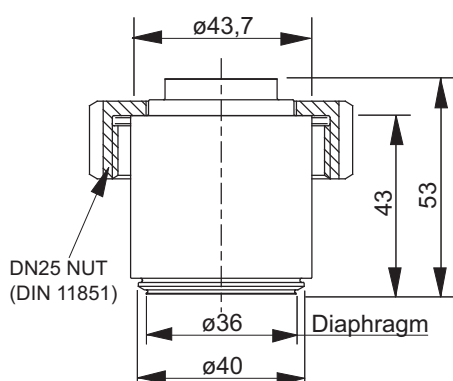

## CONNECTION DIAGRAM

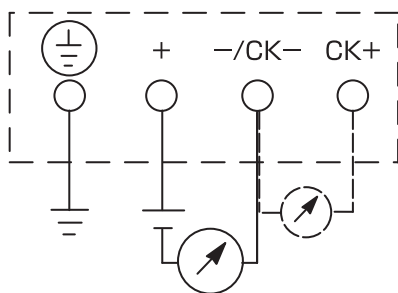
**EMC Directive (2004/108/EC)**

All models of **FCX** series transmitters type **FCX-AII** are in accordance with :

• the harmonized standards:

- EN 61326-1 : 2006 (Electrical equipment for measurement, control and laboratory use - EMC requirements).
- EN 61326-2-3 : 2006 (Part 2-3 : Particular requirements - Test configuration, operational conditions and performance criteria for transducers with integrated or remote signal conditioning)

**Emission limits** : EN 61326-1 : 2006

Frequency range (MHz)	Limits	Basic standard
30 to 230	40 dB ( $\mu\text{V/m}$ ) quasi peak, measured at 10m distance	EN 55011 / CISPR 11 Group 1 Class A
230 to 1000	47 dB ( $\mu\text{V/m}$ ) quasi peak, measured at 10m distance	

**Immunity requirements** : EN 61326-1 : 2006 (Table 2)

Phenomenon	Test value	Basic standard	Performance criteria
Electrostatic discharge (EDS)	4 kV (Contact)	EN 61000-4-2	<b>B</b>
	8 kV (Air)	IEC 61000-4-2	
Electromagnetic field	10V/m (80 to 1000 MHz)	EN 61000-4-3	<b>A</b>
	3 V/m (1.4 to 2.0 GHz)	IEC 61000-4-3	
	1 V/m (2.0 to 2.7 GHz)		
Rated power frequency Magnetic field	30 A/m	EN 61000-4-8 IEC 61000-4-8	<b>A</b>
Burst	2 kV (5/50 NS, 5 kHz)	EN 61000-4-4	<b>B</b>
		IEC 61000-4-4	
Surge	1 kV Line to line 2 kV Line to line	EN 61000-4-5	<b>B</b>
		IEC61000-4-5	
Conducted RF	3 V (150 kHz to 80 MHz)	EN 61000-4-6	<b>A</b>
		IEC61000-4-6	

Performance criteria :

**A** : During testing, normal performance within the specification limits.

**B** : During testing, temporary degradation or loss of function or performance which is self-recovering.



**Fuji Electric France S.A.S.**

46 rue Georges Besse - ZI du brézet - 63039 Clermont ferrand

Tél : 04 73 98 26 98 - Fax : 04 73 98 26 99

Mail : sales.dpt@fujielectric.fr - web : www.fujielectric.fr

Fuji Electric can accept no responsibility for possible errors in catalogues, brochures and other printed material. Fuji Electric reserves the right to alter its products without notice. This also applies to products already on order provided that such alterations can be made without subsequential changes being necessary in specifications already agreed. All trademarks in this material are property of the respective companies. all rights reserved.